

## TECHNICAL DATA SHEET BACKSPLASHES & UPSTANDS



## 1. Backsplashes & Upstands

There are different possibilities of backsplashes (up stand) in different designs and manufacturing costs involved. The different design can be fabricated in different manufacturing processes - depend-ing on the methods to be chosen. The Standard backsplash (Fig.1) is a strip of HIMACS trimmed off with a radius of ca. 6mm and fixed with acrylic based silicon adhesive.

To avoid any build up moisture or bacteria the curved backsplash (Fig.2) recommended as the most ideal solution, especially in wet areas, like sinks or vanities. But also many other applications can be designed in a way that 's easy to clean

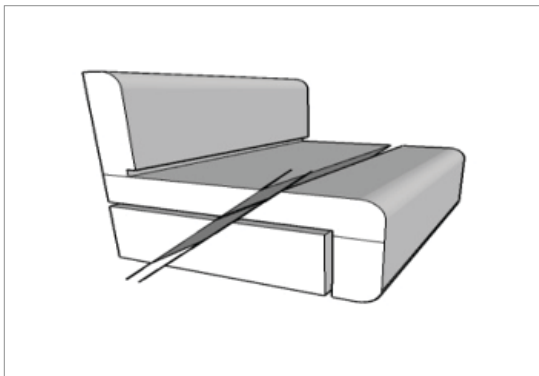

Fig.1



Fig.2

### 1.1. How to create a curved backsplash

Sample: step by step

Make a rebate on the back of a counter top (Fig.3)

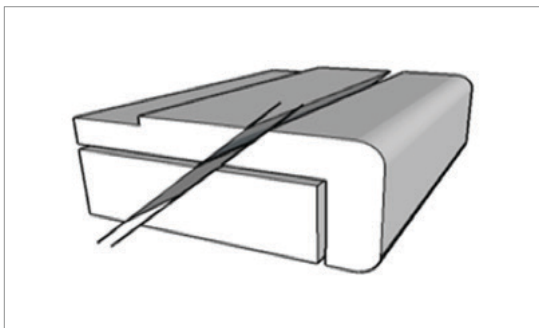

Fig.3

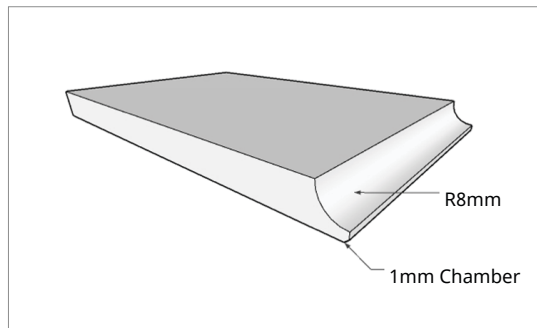

Fig.4

Trim a radius ( $r = 8\text{mm}(10\text{mm})$ ) on a strip of HIMACS with a width of approx. 160mm (Fig.4). Cut the right length off ( $w = 20\text{mm}(22\text{mm})$ ) from your 160mm wide strip (Fig.5).

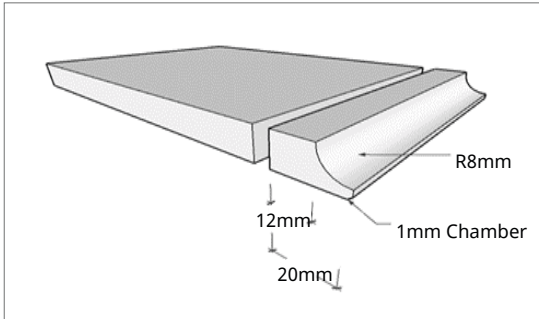

Fig.5

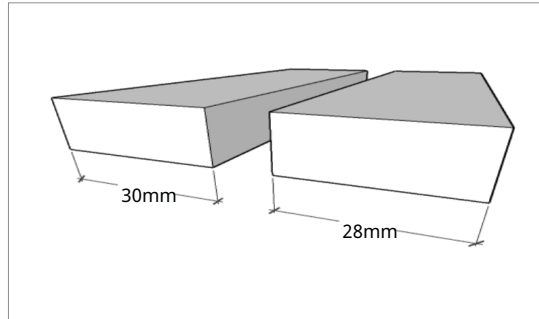

Fig.6

Cut a piece for the up stand: (30mm(28mm) (Fig.6). Put a female profile on the strip with the curve (Fig.7). Put the male profile on the up stand (Fig.8).

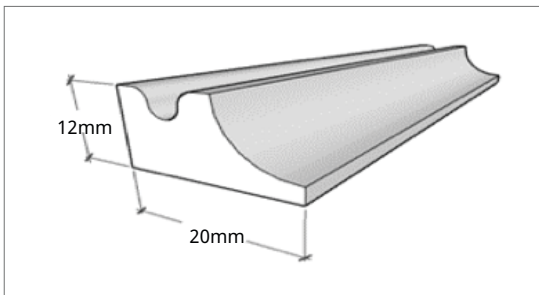

Fig.7

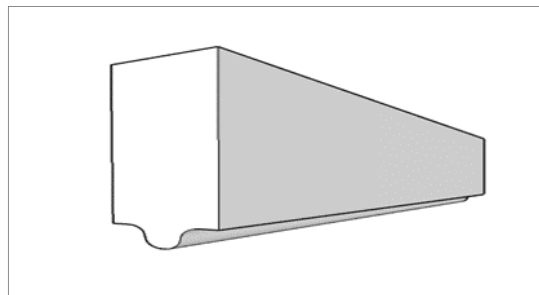

Fig.8

Bond the strip of the curve (Fig.7) and the Upstands (Fig.8) together (Fig.9). After curing time sand it and finish it off. Leave at least a minimum of a 2mm step. Never run against "0"mm(Fig.10).

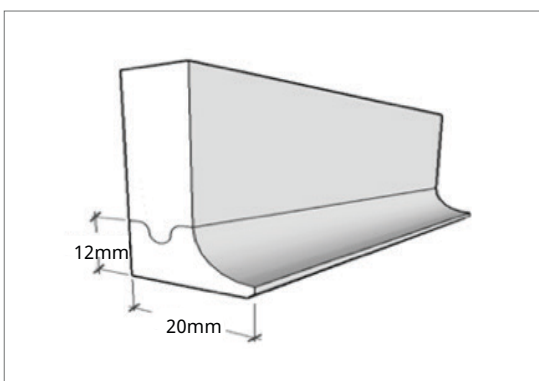

Fig.9

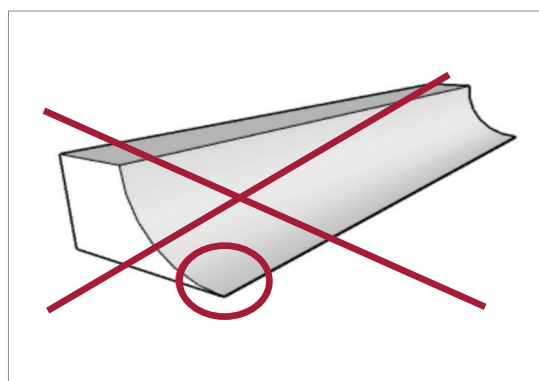

Fig.10

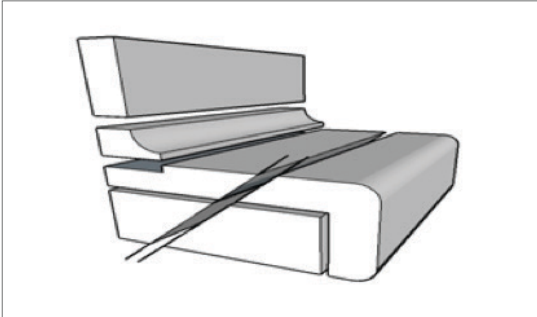

Fig.11

Insert the curved backsplash into the counter top (Fig.11) and finish off by trimming and sanding according to the guidelines.

**Hint:**

Before bonding the curved backsplash into the counter, apply an arris to the edge of the curved section.

## 1.2. Inside corner

To set up a inside corner, prepare a corner piece according to the radius you have chosen – here radius (R8). Based on a standard height prepare a block long enough to cut off later a smaller block of 20mm x 20mm x 42mm. On a special router prepare the inside radius or plunge in with a router bit after positioning and gluing (Fig.12, Fig.13).

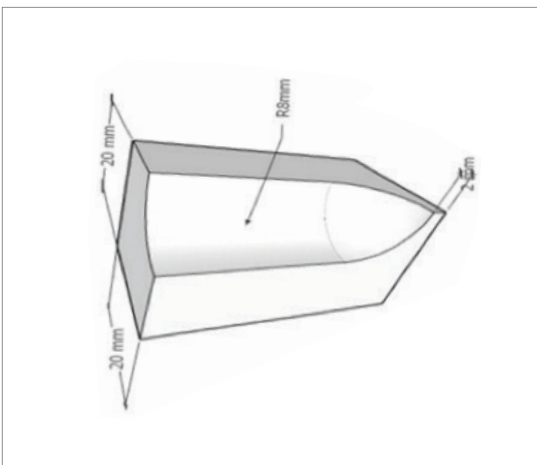

Fig.12

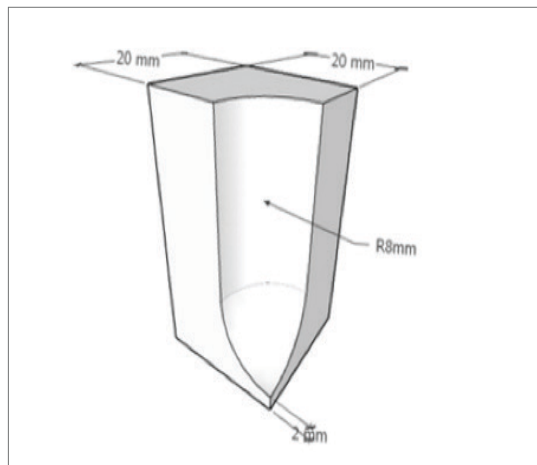

Fig.13

### 1.3. Outside corner

Prepare a standard curved backsplash and put your standard radius on the outside edge (Fig.14)– left or right hand side. Finish off by sanding to a semi-gloss level. To ensure homogenous surface use HIMACS only.

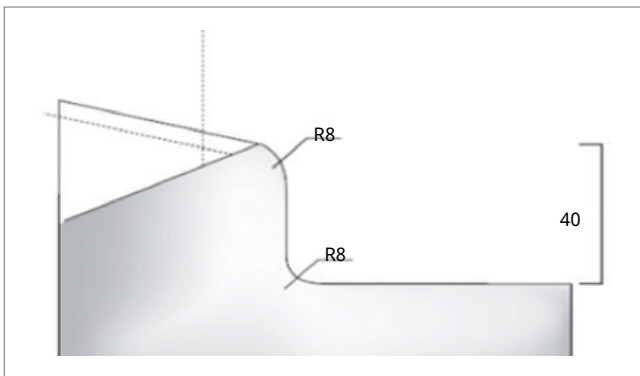

Fig.14

## 2. Color Family Pattern

Due to the wide offering of different pattern the recommended curved backsplash method can not become used by all HIMACS available color families.

Especially following color families cannot be recommended to produce this above described fabrication method as the larger chips used are based on the surface or has different levels of color in the sheet thickness, like:

- Quartz (some pattern)
- Granite (some pattern)
- Marmo / Aurora
- Aster
- Sparkle
- Lucia
- Volcanics
- Strato
- Terrazzo

**Hint:**

Please check and prepare a sample first of how it would look a like. Not every customer may does like it.

When preparing a curved upstand or downturn, customers may not accept the final result. One may not compare, though with Solid colours used in the kitchen market. A downturn or an upstand are best achieved with a 45° angle or a profiled folding option – see Fig.15 and Fig.16 (V-grooving).

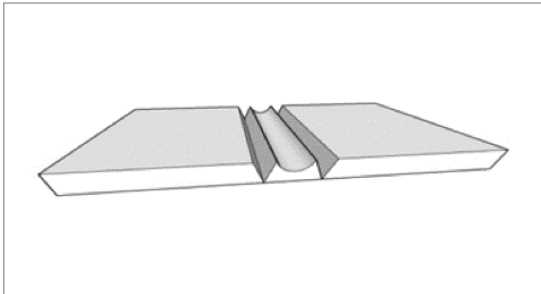

Fig.15

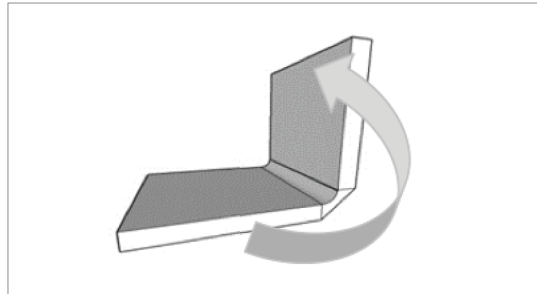

Fig.16

A covered backsplash of MARMO may become very visible as shown in Fig.17. The random veining structure fades near to both long edges of the sheet and a colour inconsistency may appear.



Fig.17

For such color families an outside corner of the Upstands a 45° angle with a small radius of 1 or 2mm on the front edge is perhaps more convenient and more customer friendly.

## Disclaimer

The information provided in this specific technical bulletin corresponds to our best knowledge on the subject at the date of its publication. This information may be subject to revision as new knowledge and experience becomes available. The data provided fall within the normal range of product properties and relates only to specific material designated. These data may not be valid for such material in combination with other materials or in any process, unless expressly indicated otherwise. It is offered exclusively to provide possible suggestions for your own experiments and needs our approval for Warranty.

This Technical Document is not intended to replace for any testing you may need to conduct to determine for yourself the suitability of our products for your particular purpose. Since we cannot anticipate all variations in actual end-use conditions, We make no warranties and assume no liability in connections with any use of this information. Nothing in this publication is to be considered as a license to operate under or a recommendation to infringe any patent right.

## ■ LX Hausys Europe GmbH

European Headquarters:  
LX Hausys Europe GmbH  
Lyoner Str. 15 60528  
Frankfurt am Main, Germany

